

## REMOVING AND REPLACING CONTROL UNIT

MODELS: 250SX, 250SXO, 635ES, 635ESO



### WARNING

LP & NG ARE EXTREMELY FLAMMABLE SO TAKE EXTRA PRECAUTIONS WHEN PERFORMING ANY WORK TO THE HEATER

Before removing the control unit the original fan speed settings must be recorded so they can be programmed into the new control unit.

### Recording fan speeds (Refer to Fig 1 below).

1. Ensure the unit's on/off switch is in the off position.
2. While depressing and holding the "M" program button turn the power switch to the on position.
3. Release the "M" button **immediately** when you see 188 on the display.
4. P2 will then be shown on the display.
5. Press the "M" button to view the fan speed setting for P2, record the number (normally between 10 and 15).
6. P2 = \_\_\_\_\_
7. Press the "M" button again, P2 will appear on display.
8. Press the + button until P1 appears.
9. Press the "M" button to view the P1 fan speed setting, record the number (normally between 46 and 53).
10. P1 = \_\_\_\_\_

FIGURE 1

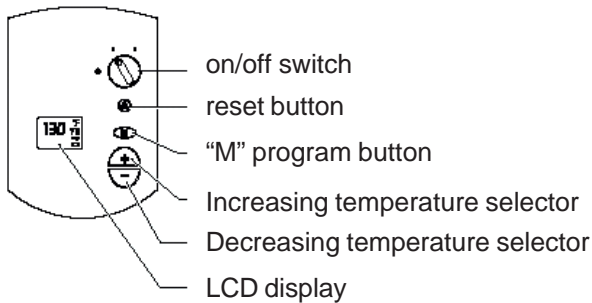

### You are now ready to remove the control unit.

1. Disconnect power supply to heater.
2. Remove plastic decals on front panel.
3. Loosen two Philips head screws located behind plastic decals.
4. Lift front cover upward and remove.
5. Remove control box auxiliary cover (Fig 2, pos. 4)
6. Remove the 5 screws on the front retaining bar (see Fig 2, pos. 1 and 2) being careful not to damage the foam sealant material on it.
7. Remove the two electrical strip connectors inside the unit (Fig 3) and then loosen the 110V power supply cord retaining nut located underneath the heater. Once loosened, the power cord can be pulled up through the heater to provide sufficient slack.

FIGURE 2

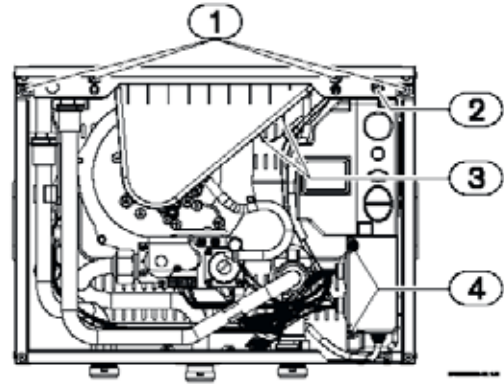

8. At the ignition electrodes, pull off the 2 yellow igniter wires that come from the top of the control unit (Fig. 2 pos. 3). Then pull the complete control unit forward and out of the heater, pull up the power supply cord further if more slack is needed.

FIGURE 3



Once auxiliary cover is off, pull off the two electrical strip connectors inside the board. Once off, the wiring strands can be removed from the area of the board by pulling their rubber seals outward.

9. While holding the control unit in one hand or resting it on a flat surface, remove the front cover of control unit by removing its 4 screws.
10. Locate electrical connections and ground inside control unit, disconnect, taking notice of black and white wire location. Remove cord connector from control unit.

## REMOVING AND REPLACING CONTROL UNIT

### Replacing control unit

1. Replace cord connector and reinstall black, white and ground wires to appropriate locations.
2. Replace the front cover to the control unit and reinsert into heater and proceed with previous steps in reverse order. When reconnecting the electrical strip connectors to the new control unit, be sure to connect the larger (2") connector to the lower position on the circuit board and the smaller (15/8") connector to the upper position. Be sure that the rubber seals of the electrical strip connectors are in place and the 2 yellow igniter wires get reconnected.
3. Replace retaining bar.
4. Replace front cover panel and plastic decals.
5. Connect power to heater, display will cycle and 122 will show on display.

### Programming fan speeds

1. Turn the on/off switch to the off position.
2. While depressing and holding the "M" program button turn the power switch to the on position.
3. Release the "M" button **immediately** when you see 188 on the display.
4. P2 should show on the display.
5. Press the "M" button to view the fan speed setting for P2, then press + or – to change display to the fan speed previously recorded. (normally between 10 and 15).
6. Press the "M" button until the number flashes for 3 seconds then release.
7. Press the "+" button until P1 appears.
8. Press the "M" button to view the P1 fan speed setting, then press + or – to change display to the number previously recorded (normally between 46 and 53).
9. Press the "M" button until the number flashes for 3 seconds then release.
10. Repeat the programming steps to ensure the proper values are locked in for P1 and P2.