

## REPLACING AND CLEANING ELECTRODES

MODELS: 250SX, 250SXO, 635ES, 635ESO



### WARNING

LP & NG ARE EXTREMELY FLAMMABLE SO TAKE EXTRA PRECAUTIONS WHEN PERFORMING ANY WORK TO THE HEATER

### Removing Electrode Set

1. Turn off gas to heater using installer supplied manual shut off valve.
2. Turn power switch to the off (O) position and unplug heater.
3. Remove cover per chapter 4 in installation manual.
4. Remove brass phillips-head screws to release holding bracket (Fig. 1).
5. Remove air intake duct: remove two philips-head screws on the bottom of the air intake duct and then pull forward (Fig. 1). NOTE: There is a thin black o-ring between the air intake duct and the gas/air mixer that may fall out.
6. Disconnect three yellow wires connected to the bottom of the electrode set (Fig. 2).
7. Remove two 8mm retaining nuts (Fig. 2).
8. Lower the electrode set slowly and rotate inward to remove (see Fig.3 for picture of electrode set).

### Replacing Electrode Set

1. Gently place new gasket on studs. The studs will hold the gasket in place.
2. Carefully feed tips of electrode set into bottom of burner bed and rotate out while inserting.
3. Ensure proper seal between bottom of burner bed and the electrode set.
4. Replace the two 8mm retaining nuts (Fig. 2).
5. Connect the two similar yellow wires to the left and center terminal (ignitor rods) (Fig. 2). Connect the thinner yellow wire to the right terminal (Flame sensor) (Fig. 2). Ensure the connectors fit snugly on the terminals.
6. Place thin black o-ring around the outside lip of the gas/air mixer.
7. Push air intake duct in place with two hands and hold. Ensure the top of the air intake duct is level and the back rubber gasket is tucked under the bed.
8. Replace two phillips-head screws on the bottom of the air intake duct (Fig. 1).
9. Replace holding bracket (Fig. 1) and cover.
10. Plug unit in and turn power switch to on (I) position. Reset any error that is displayed.
11. Open manual gas shut off valve.
12. Return to service.

FIGURE 1

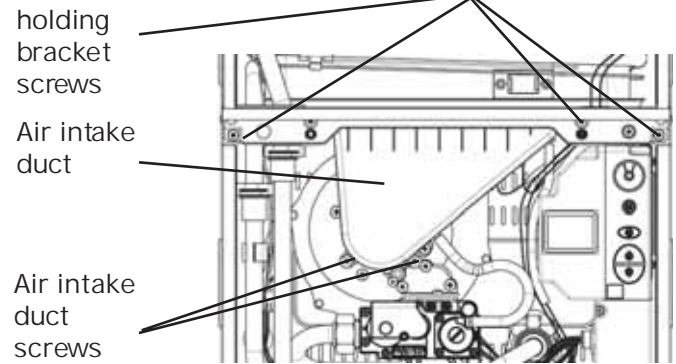

FIGURE 2

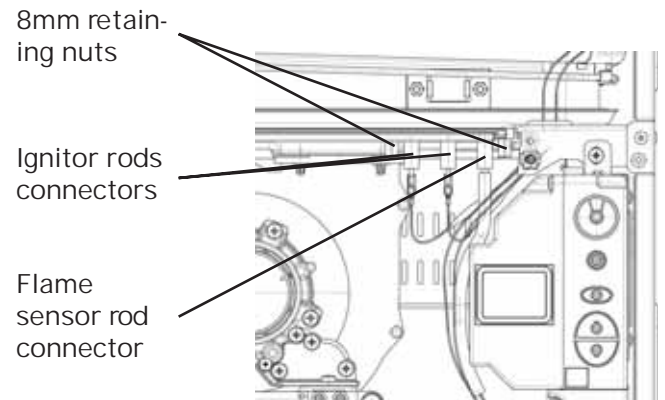

FIGURE 3

### Cleaning Electrode Set

1. If electrode set gasket is discolored or torn, replace with a new gasket.
2. Using steel wool, gently polish all surfaces of the flame sensor rod and electrodes.

